

# Operations Manual

## **Model 222**

Serial Number 030410003

**April 10, 2003**



6147 Clark Center Avenue 34238  
Phone: 941-926-2454 Fax 941-926-2461

## Table of Contents

2.	<b>Glossary</b> .....	1
3.	<b>General Description</b> .....	1
4.	<b>General Characteristics</b> .....	2
5.	<b>Installation</b> .....	3
6.	<b>Adjustments</b> .....	4
7.	<b>Theory of Operation</b> .....	5
8.	<b>Maintenance</b> .....	7
9.	<b>Parts List</b> .....	12
10.	<b>Electrical</b> .....	13
11.	<b>Schematic</b> .....	13
12.	<b>Assembly Drawing and Parts Locator</b> .....	16

### 2. Glossary

d.c.	Direct Current
DIL	Dual In-Line
led	Light Emitting Diode
Megger	Meg Ohmmeter
msec	millisecond
pk-pk	Peak to Peak
uH	Micro henry
uF	Micro farad

### 3. General Description

The Northstar Controls Model 222 Loop Sensor is a dual channel unit designed for use in an standard 170 input file. The 222 features an international size card with double sided 44 pin gold edge connector for the connection of power, loops, and call outputs. The loop inputs are designed to be connected to a wide range of loop and lead-in arrangements with inductances between 20 and 2000 microhenries. Lead-in lengths of over 2000 feet are possible with the correct loop size attached.

Front panel DIL switches allow the user to adjust sensitivity individually for each channel, one of eight sensitivity levels may be selected to tailor the sensor unit to the application. Four frequency levels are available to alleviate interference from other sensor units close by. The use may also select from two operational modes: Pulse mode or Presence.

Dual led indicators per channel are used to indicate detection calls and current or historical loop events. A single led indicator displays the condition of the EOS switch.

Detection call outputs are made by means of optically isolated solid state transistor and are designed to be compatible with 170 standard inputs.

## 4. General Characteristics

The 222 loop sensor unit incorporates the following general characteristics.

The Loop Inputs are transformer Isolated and capable of withstanding a 2000 Volt discharge from a 10uF capacitor across the loop connections or from either loop input to ground. The loop inputs will allow operation when the external loop or lead-in is shorted to ground at a single point.

The loop inputs may be connected to any single or multiple loop configuration which provides a total inductance at the loop inputs between 50 and 700 uH with a Q factor of at least 5.

Front panel DIL switches control Sensitivity, Operational Mode and Frequency.

Four frequency settings are available using two front panel DIL switch positions and may be used to alleviate crosstalk between adjacent loops connected to different sensor units. Loops that are closest together and have the same dimensions have the greatest likelihood of mutual interference thus the ability to alter the operating frequency of one or both of the channels is important.

Three DIL switch positions allow the selection of one of seven sensitivity levels. Level 0 is used to disable the channel. Sensitivity determines the inductance change that a vehicle must create when it enters the zone of detection for it to be detected by the sensor unit.

Operational Mode determines the nature of the output signal that the sensor unit channel produces in response to a vehicle detection. Two modes are available: pulse mode, and presence mode.

Pulse mode provides a single 125 millisecond pulse output in response to a vehicle detection. If a vehicle remains within the detection zone then further outputs are inhibited for a period of two seconds after which subsequent vehicle detections caused by vehicles entering the uncovered portion of the detection zone will be detected and pulse outputs produced.

Presence mode provides a constant signal indicating the presence of a vehicle up to 120 minutes. The output signal will terminate immediately when the vehicle leaves the detection zone. If a vehicle should remain for a period longer than 120 minutes the vehicle presence will be tuned out and the output signal will terminate.

If a sensor channel is not to be connected to a loop, it may be disabled, its loop oscillator will be turned off and no output or indicators will be operational. To enable the channel, the sensitivity should be selected for a sensitivity between 1 and 7.

Board mounted DIL switches are used to determine special operating conditions. The Minimum presence switch when ON ensures a minimum 100 millisecond presence output from the sensor channel irrespective of the length of time the vehicle actually remains within the detection zone. If the switch is turned OFF, the minimum presence requirement

is removed. The EVENT O/P switch when in the ON position ensures that the sensor channel will produce a detect call during a loop event condition. Turning the switch OFF prevents the sensor from producing a detect call under such a condition. The front panel EOS led indicates the position of the EVENT O/P switch.

The call outputs for each channel are solid state optically isolated transistors which are protected from over voltage and reverse polarization by zener protection diodes.

## 5. Installation

The Northstar Controls Model 222 is designed to be installed in a 170 type input file. Connections to power, loops and call outputs should be made from the rear of the input file to the correct locations in the cabinet.

Select the desired positions of the board mounted DIL switches for MINIMUM PRESENCE and EVENT O/P.

When installed in the input file the front panel DIL switches may then be set for the desired sensitivity and operational mode.

### Sensitivity

Each channel has seven available sensitivities and a channel disable position which will allow the user to configure the channel for a wide array of loop sizes and configurations as well as fine tuning the installation to cater for special circumstances such as lead-in length or response time.

The sensitivity is set using three DIL switch positions designated S0/S1, S0/S2 and S0/S4. The combination of these switches in a binary sequence determines the sensitivity level. Setting 0 is the lowest sensitivity and Setting 7 is the highest. Normal sensitivity is setting 4 which is used for most applications. Observe traffic passing entering the detection zone and make adjustments to the sensitivity one setting at a time.

Level	DIL switch positions			% DL/L	Response Time msec
	S0/S4	S0/S2	S0/S1		
0	OFF	OFF	OFF	Channel OFF	-
1	OFF	OFF	ON	0.64	3 $\pm$ 1
2	OFF	ON	OFF	0.32	4 $\pm$ 1
3	OFF	ON	ON	0.16	5 $\pm$ 1
4	ON	OFF	OFF	0.08	8 $\pm$ 2
5	ON	OFF	ON	0.04	14 $\pm$ 4
6	ON	ON	OFF	0.02	30 $\pm$ 6
7	ON	ON	ON	0.01	50 $\pm$ 10

### Operational Mode

One DIL switch position selects Pulse or Presence mode.

In pulse mode, the sensor channel will produce a 125 millisecond pulse indication upon the entry of a vehicle in the detection zone. If a vehicle should remain in the detection zone, further pulses will be inhibited for a period of two seconds after which pulse indications will be produced for vehicles entering the unoccupied portion of the detection zone.

In presence mode the channel will detect and hold the presence of a vehicle in the detection zone. When the detection zone clears once more the detection indication will cease. The length of time that the detection indication will remain is also dependent upon the sensitivity setting and the size and type of the vehicle. The maximum presence time is 120 minutes.

### Frequency

Four frequency settings are available to alleviate issues of crosstalk or interference from neighboring sensor units connected to adjacent loops. Two DIL switches designated F0/F1 and F0/F2 can be set as follows.

F1 + F2 = High Frequency

F0 + F2 = Medium High

F1 + F0 = Medium Low

F0 + F0 = Low Frequency

If crosstalk is observed between different channels on adjacent sensor units then adjust the frequencies on the affected channels to effect the greatest frequency differential possible between them.

If the frequency is changed or if a spurious detection signal appears on initial power up or insertion of the sensor unit into the input file, first ensure that there are no vehicles in the detection zone then select channel OFF and return to ON to reset the call.

Observe traffic movement and the detect indicators to ensure satisfactory operation.

## **6. Adjustments**

No special adjustments are required on the Northstar Controls Model 222 Loop sensor

## **7. Theory of Operation**

### **a. Systems Description**

The Northstar Controls 222 sensor unit consists of the following major circuit elements: The loop oscillators, one per channel, The digital period measurement circuit, the microcontroller, the front panel switches and indicators and the output circuits

The loop oscillator, when connected to a suitable road loop / lead-in combination, establishes an oscillating signal the frequency of which is directly related to the inductance of the loop and lead-in. When a vehicle enters the detection zone surrounding the loop, the inductance of the loop changes causing the frequency of the oscillating signal to change and providing a means to determine the presence of the vehicle. Transient protection elements are incorporated within the oscillator to prevent large transients from causing damage to the oscillator or other electronics.

The oscillator in each channel is energized in turn preventing the possibility of mutual interference between the channels. Frequency switches accessible from the front panel allow the operating frequency of the oscillator to be modified to prevent mutual interference between oscillators associated with different sensor boards connected to adjacent loops.

When a channel is energized, a sample of the frequency is taken and compared to a stored reference. Sensitivity switches accessible from the front panel allow the adjustment of sensitivity which determines the amount of change in frequency that is required between the current sample and the reference to result in a detect call being made.

The detection call output for each sensor channel is made by means of a solid state optically isolated transistor which is set to conduct to indicate a vehicle detection. Front panel led indicators also indicate a vehicle detection and also when the inductance of the road loop exceeds the operating range. The call output may be set to provide a call or no calls during the time that the road loop exceeds the operating range by means of a board mounted EVENT O/P switch.

A board mounted DIL switch position is also provided to ensure a minimum 100 millisecond output call duration in response to a vehicle presence. Switching this switch to OFF disables this requirement.

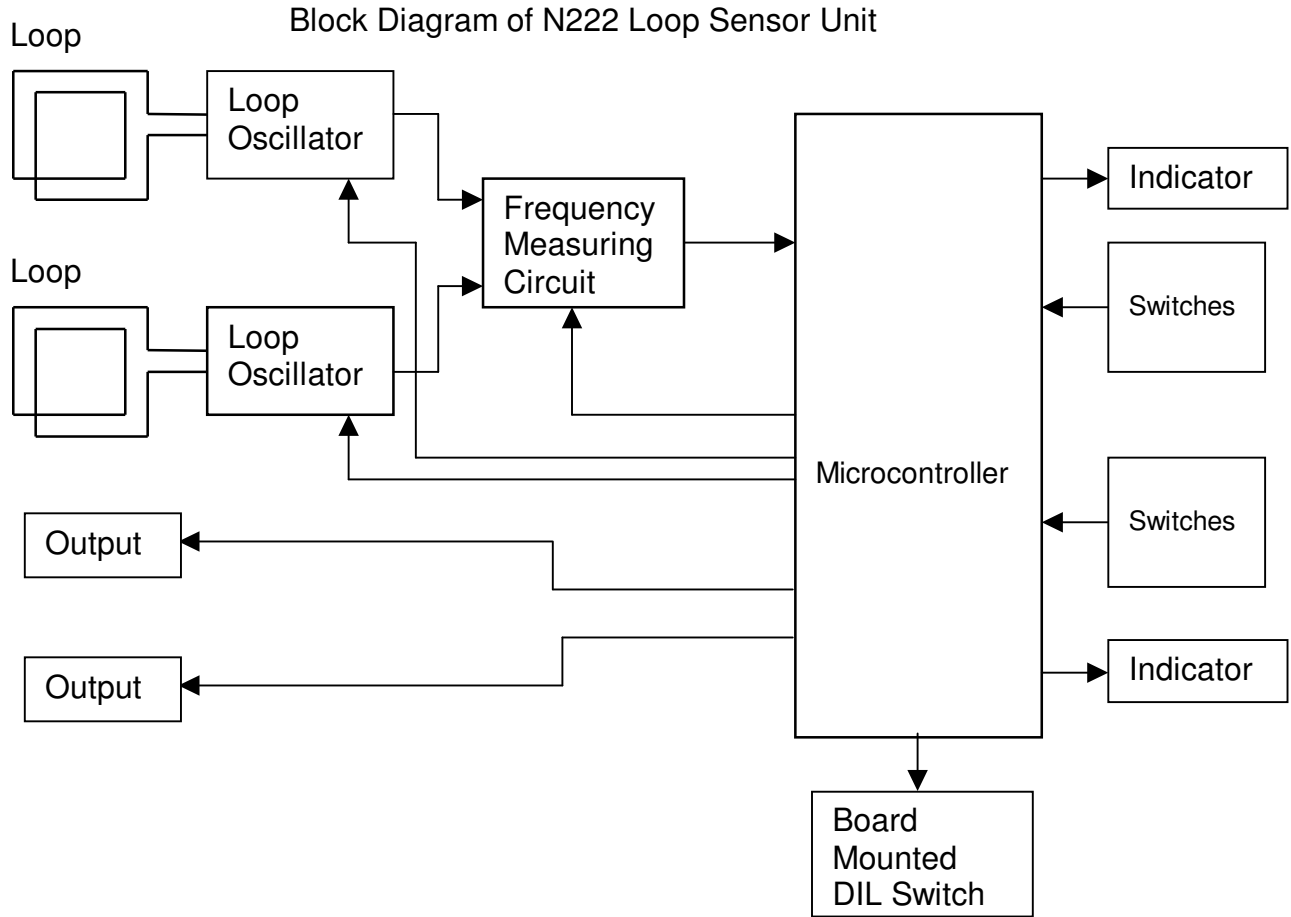

**b. Detailed Description of Operation**

When power is applied to the sensor unit, the microcontroller first checks the condition of the front panel switches to determine which channels are enabled, what sensitivity level is set and what operational mode is required. The condition of the board mounted DIL switch is also checked and the parameters stored in the microcontroller. The EOS led is lit if the EVENT O/P switch is ON. Then in turn, first one loop oscillator, then the other is activated to obtain a sample of the loop frequency.

When the loop oscillator is activated the combination of the inductance of the road loop and the added capacitance within the oscillator circuitry produces a resonant frequency. The oscillating signal in the road loop sets up an alternating magnetic field surrounding the loop itself. When the conductive metal in a vehicle enters the magnetic field it acts in a similar manner to a shorted turn and the effective inductance of the loop is reduced thus increasing the resonant frequency.

Frequency modification switches at the front panel allow the oscillator frequency to be modified when multiple loops and multiple sensor units are operated close to each other. This prevents interference or crosstalk from occurring between loops connected to different sensor units. A loop transformer within the oscillator circuitry isolates the road loop from the internal circuitry of the sensor improving its resistance to external surges

induced in the road loop and also allowing the sensor to operate with loops that are shorted to ground.

The sinusoidal oscillations are fed through a squaring circuit to produce a square wave which is suitable for the digital frequency measurement circuitry. The loop oscillator frequency is measured by counting the number of oscillations from a stable crystal oscillator source which occur over a predetermined number of loop oscillator cycles. This is known as period measurement and defines the frequency of the loop oscillator to a very fine resolution. A combination of the loop frequency and the selected sensitivity is used to determine the number of cycles over which to perform the period measurement.

Once a stable oscillator condition has been established the sample is stored as a reference against which subsequent samples will be compared. Small, slow changes in the oscillator frequency due to environmental drift are programmed out allowing the direct comparison of fast changes due to the entry of a vehicle in the detection zone. Once a period shift exceeding the detection threshold set by the sensitivity level occurs, the output and detect indicator for that channel are activated. The Operational mode that was set on the front panel switches will determine whether a single 125 millisecond output pulse is issued (pulse mode) or whether the output signal remains until the oscillator frequency returns below the detection threshold indicating the exit of the vehicle from the detection zone (Presence mode).

If the loop oscillator frequency exceeds the operating range of the sensor unit, as might happen when the road loop connection is open or short circuited then a fault condition is signaled by the detect output entering the state defined by the EVENT O/P switch, the Event led lighting solid yellow and the detect led indicators flashing. If the oscillator frequency should then return to within the operating range, the detect output and led indicator will return to their normal operating state while the yellow Event indicator will continue to flash indicating that a historical fault has occurred. The flash sequence indicates the type of fault that was sensed. A single flash followed by a pause indicates an open circuit loop or the loop inductance is too large. A double flash followed by a pause indicates a shorted loop or too small a loop inductance.

The sensor unit is designed to operate from a 24 Volt d.c. supply and will operate at supply voltages between 19.2 and 28.8 volts with a supply ripple of at least 700 millivolts. If the supply voltage should be below that needed for correct operation the sensor unit will enter a reset state until the supply returns to its correct level.

## **8. Maintenance**

### **a. Preventive Maintenance.**

The Northstar Controls Model 222 does not require maintenance.

### **b. Trouble Analysis.**

Trouble analysis may be divided up into two major areas. Sensor based problems and Loop based problems. Sensor based problems can be traced to power supply, input file or backplane or the sensor unit itself. Loop based problems can be traced to wiring, splices and the condition of the loop itself.

### c. Trouble Shooting Sequence Chart

<b>Problem</b>	<b>Possible Cause</b>	<b>Solution</b>
<b>No Detect Indications even when vehicles cross the detection zone</b>	Sensitivity too low	Increase Sensitivity by one setting at a time.
	Loop Problem	See Loop Based Problems
	No power	Check supply voltage at pin B of the edge connector. Supply voltage must be between 18.2 and 28.8 volts d.c. If the supply voltage is too low then remove sensor units until the supply voltage returns to within the acceptable range. The last unit removed may have a fault.
	Channel Disabled	Make sure ON/OFF switch on front panel is set to ON
	Sensor Unit is in Reset	Remove sensor units from input file one at a time until vehicle detection indications are observed on remaining sensor units. The last sensor unit removed has a reset line fault.
<b>Permanent detect indication even when no vehicles are present</b>	Frequency setting was changed or detector newly installed causing an erroneous detection	Select channel OFF then return to channel ON to reset the detection call.
	Possible crosstalk between loops connected to different sensor units	Change frequency setting and reset by selecting channel OFF and returning to ON again.
	Possible loop problem	See loop based problems
<b>Intermittent detection indications with no vehicles present</b>	Possible crosstalk between loops connected to different sensor units	Change frequency setting and reset by selecting channel OFF and returning to ON again.
	Possible loop problem	See loop based problems
<b>Both detect and fault indicators blinking</b>	Possible loop problem	See loop based problems
<b>Fault indicator blinking</b>	Possible loop problem	See loop based problems

## Troubleshooting Loop Based Problems

Problem	Possible Cause	Solution
<b>No Detect Indications even when vehicles cross the detection zone</b>	Loop too small or parallel connected loop has become disconnected.	Check all loop connections. Make sure connections are solid, preferable soldered and waterproofed.
<b>Permanent detect indication even when no vehicles are present</b>	Poor loop connections or loop/lead-in may be able to move in slot/conduit	Check condition of loop for loose wires or untwisted sections of lead-in. Ensure loop wires and lead in cannot move. Check all loop connections. Make sure connections are solid, preferable soldered and waterproofed.
	Intermittent short to ground causing erroneous detection	Check loop impedance to ground with Megger. Impedance should be greater than 20Mohm at 500Volts
<b>Intermittent detection indications with no vehicles present</b>	Poor loop connections or loop/lead-in may be able to move in slot/conduit	Check condition of loop for loose wires or untwisted sections of lead-in. Ensure loop wires and lead in cannot move. Check all loop connections. Make sure connections are solid, preferable soldered and waterproofed.
	Intermittent short to ground causing erroneous detection	Check loop impedance to ground with Megger. Impedance should be greater than 20Mohm at 500Volts
<b>Fault indicator is solid yellow and detect indicator blinks with single blink followed by a pause</b>	Open circuit loop.	Check all loop connections specially in pull boxes or at terminal strip. Look for splices that have become open.
<b>Fault indicator is on solid and detect indicator blinks with double blink followed by a pause</b>	Short Circuit Loop	Check all loop connections specially in pull boxes or at terminal strip. Look for shorts between bare loop wires. Look for splices that have become shorted.
	High series impedance	Check series impedance of loop using Multimeter. Series impedance should be less than 10 ohms. Check all connections for poor splices or dirty and corroded terminals.
<b>Fault indicator blinking</b>	Intermittent Loop problem that has self healed temporarily	Check as for other loop based problems.

#### d. Voltage Measurements and Waveforms

When measuring voltages on the Northstar Controls model 222 it will be necessary to ensure that the unit is placed on a non-conductive surface and simulated loops of approximately 100 microhenries inductance must be connected to the loop terminals at the edge connector. All measurements are referenced to Logic ground pin A at edge connector. Select sensitivity 2 and high frequency on both channels.

1. Connect power supply of between 18.2 and 28.8 Volts d.c. to the edge connector pin B. Connect loops to both channel 1 (pins D & E) and channel 2 (pins J & K).
2. Regulated 5 V supply. Voltage at positive end of C3 should be 5 Volts +/- 0.2 V
3. Reset Voltage. Voltage at pin 1 of microcontroller U4 should be 5 Volts +/- 0.2 V
4. Crystal Oscillator. Signal at pin 10 of U4 should be a sine wave at 20MHz and between 2.5 and 4V pk-pk as in figure 1.
5. Loop oscillator control signal. The signal at U4, pin 4 (channel 1) and 5 (channel 2) should be as in figure 2.

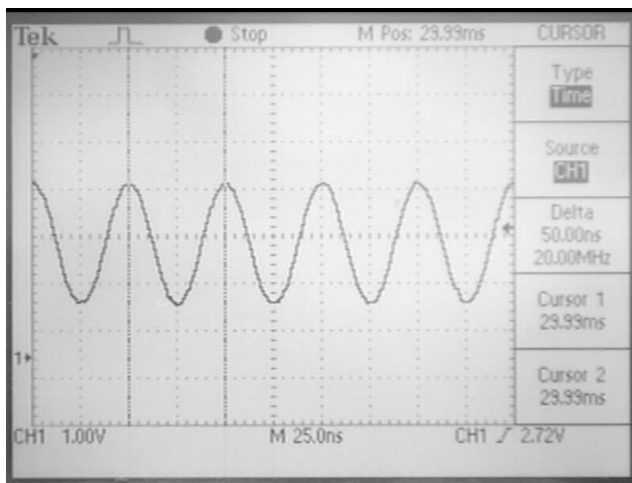

Figure 1

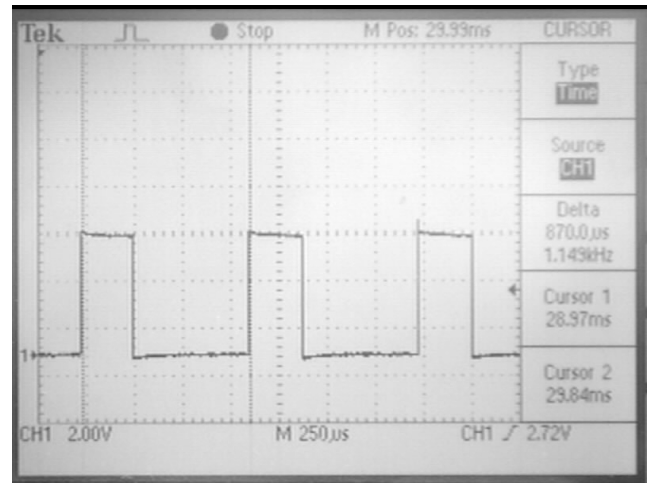
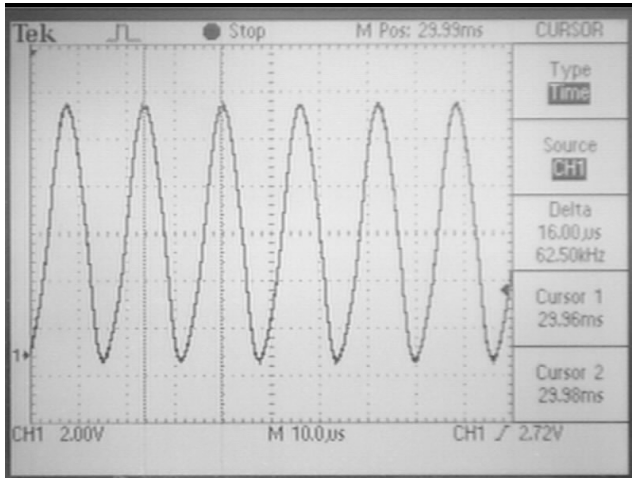

Figure 2

6. Loop Oscillator signal. The signal at the zener surge absorber D9 (Ch.1) and D11 (Ch.2) should be a sine wave of approximately 8 to 12 Volts pk-pk as shown in Figure 3.

7. Squared Loop Oscillator signal. The signal at U5 pin 3 (channel 1) and pin 6 (channel 2) should be a square wave as shown in Figure 4.



**Figure 3**

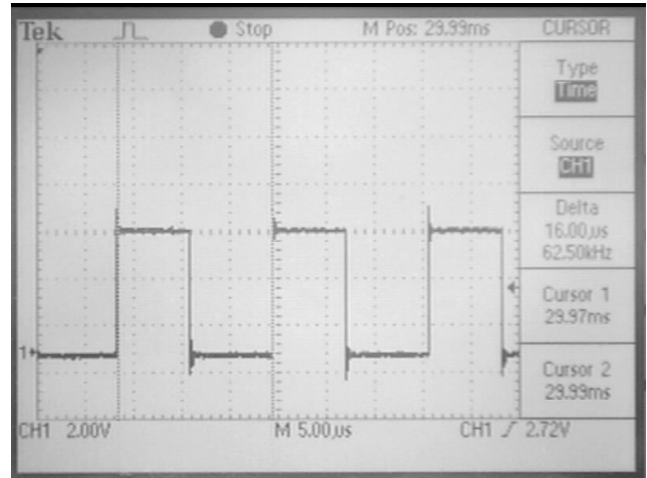

**Figure 4**

## 9. Parts List

Item	Qty	Ref. Des.	Description	Manufacturer
1	4	Q2-3 Q6-7	Transistor, NPN, MMBT3904, SOT23	Fairchild
2	1	U2	IC, Dual D Flip-Flop, 74HC74M	Fairchild
3	1	U5	IC, Quad 2 IP Nand Schmitt, 74HC132M	Texas Instruments
4	1	U3	IC, 7 bit ripple Counter, 74HC4024M	Fairchild
5	2	Q4 Q5	Transistor, Dual NPN, BCV61A, SOT143-2	Infineon
6	1	Q1	Transistor, MOS FET, BS170, SOT23	Fairchild
7	5	C1 C4 C9-11	Capacitor, Ceramic, 0805, 0.1uF, 50V	Samsung
8	2	C15 C16	Capacitor, Ceramic, 0805, 22pF, 50V	Samsung
9	1	C2	Capacitor, Elect, 470uF, 35V, 20%	Nichicon
10	1	C3	Capacitor, Tantalum, SMD, 100uF, 10V	Samsung
11	2	C8 C12	Capacitor, PPS film, 5%, 0.047uF, 50V	Nissei Arcotronic
12	2	C7 C14	Capacitor, PPS film, 0.022uF, 50V, 5%	Nissei Arcotronic
13	2	C6 C13	Capacitor, PPS film, 5%, 0.01uF, 50V	Nissei Arcotronic
14	1	J2	Connector, 6 pin header	Samtec
15	17	D3 D6-8 D10 D12 D14 D16-23	Diode, Silicon, 50V, MMBD914	General Semiconductor
16	2	D1 D2	Diode, S1K, 800V PIV, 1A	General Semiconductor
17	2	SW1-2	Switch, DIL 6 pos, R/A, APEM DA-06T	APEM
18	1	SW3	Switch, DIL 2 pos, APEM DS02T	APEM
19	2	DS1-2	Display, Led Module Red/Yellow	Northstar Controls LLC
20	1	DS3	Display, Led Module Red	Northstar Controls LLC
21	1	VR1	IC, Voltage Regulator, 1A, LM340S-5.0, SOT263	National Semiconductor
22	2	T1-2	Loop Transformer	Northstar Controls LLC
23	2	U6-7	IC, Optoisolator, MOC8021SD	Fairchild
24	2	NE1-2	Neon, Surge Suppressor, NE2-H	Chicago Miniature
25	1	U4	IC, Microcontroller, PIC16F870 20MHz, SO28	Microchip
26	10	R9 R13-15 R17-19 R21-23	Resistor, SMT 0805, 27k, 5%, 1/16W	Samsung
27	2	R20 R27	Resistor, SMT 0805, 3.6k, 5%, 1/16W	Samsung
28	2	R12 R28	Resistor, SMT 0805, 10k, 5%, 1/16W	Samsung
29	3	R7 R16 R24	Resistor, SMT 0805, 4.3k, 5%, 1/16W	Samsung
30	6	R8 R11 R26 R29 R39 R40	Resistor, SMT 1206, 620 ohm, 5%, 1/10W	Samsung
31	1	R2 R50	Resistor, SMT 1206, 1K, 5%, 1/10W	Samsung
32	3	R10 R25 R30	Resistor, SMT 0805, 47, 5%, 1/16W	Samsung
33	1	R1	Resistor, SMT 2512, 47, 5%, 1W	ASJ
34	4	R3-6	Resistor, SMT 0805, 1K, 5%, 1/16W	Samsung
35	2	Z1-2	Diode, Zener, 47V, SMB4756	General Semiconductor
36	2	D9 D11	Diode, Tranzorb, SMBJ5.0CA	General Semiconductor
37	1	Y1	Crystal, HC49SD, 20.0000MHZ	Fox
38	1		Printed Wiring Board 1000-1222-001 Rev A	Northstar Controls LLC
39	1		Oscillator Cover	Northstar Controls LLC
40	1		Front Panel 222	Northstar Controls LLC
41	2		Bracket Keystone type 612	Keystone
42	1		Handle Keystone type 7172	Keystone
43	4		Self Tapping Screw #4	JIT Components
44	4		Machine Screw 4-40 x 1/4	Copper State Bolt & Nut

- 10. Electrical**
- 11. Schematic**





## 12. Assembly Drawing and Parts Locator

